



545 Basket Road
Webster, NY 14580

Toll Free: 800.691.0292 | Local: 585.265.1990 | Fax: 585.265.6678

www.fastenersdirect.com
sales@fastenersdirect.com

HEAVY HEX BOLTS—ASTM A193 GR B7, ASTM A307 GR A & B

Nominal Size or Basic Product Dia.	E		F		G		H			R		L			
	Body Dia.		Width Across Flats		Width Across Corners		Head Height			Radius of Fillet		Thread Length for Bolt			
	Max	Min	Basic	Max	Min	Max	Min	Basic	Max	Min	Max	Min	6 in. & shorter Basic	Over 6 in. Basic	
1/2	0.5000	0.515	0.482	7/8	0.875	0.850	1.010	0.969	11/32	0.364	0.302	0.03	0.01	1.250	1.500
5/8	0.6250	0.642	0.605	1-1/16	1.062	1.031	1.227	1.175	27/64	0.444	0.378	0.06	0.02	1.500	1.750
3/4	0.7500	0.768	0.729	1-1/4	1.250	1.212	1.443	1.383	1/2	0.524	0.455	0.06	0.02	1.750	2.000
7/8	0.8750	0.895	0.852	1-7/16	1.438	1.394	1.660	1.589	37/64	0.604	0.531	0.06	0.02	2.000	2.250
1	1.000	1.022	0.976	1-5/8	1.625	1.575	1.876	1.796	43/64	0.700	0.591	0.09	0.03	2.250	2.500
1-1/8	1.1250	1.149	1.098	1-13/16	1.812	1.756	2.093	2.002	3/4	0.780	0.658	0.09	0.03	2.500	2.750
1-1/4	1.2500	1.277	1.223	2	2.00	1.938	2.309	2.209	27/32	0.940	0.810	0.09	0.03	3.000	3.250
1-3/8	1.3750	1.404	1.345	2-3/16	2.188	2.119	2.526	2.416	29/32	0.940	0.810	0.09	0.03	3.000	3.250
1-1/2	1.500	1.531	1.470	2-3/8	2.375	2.300	2.742	2.622	1	1.036	0.902	0.09	0.03	3.250	3.500
1-3/4	1.7500	1.785	1.716	2-3/4	2.750	2.662	3.175	3.035	1-5/32	1.196	1.054	0.12	0.04	3.750	4.000
2	2.000	2.039	1.964	3-1/8	3.125	3.025	3.608	3.449	1-11/32	1.388	1.175	0.012	0.04	4.250	4.500



545 Basket Road
Webster, NY 14580

Toll Free: 800.691.0292 | Local: 585.265.1990 | Fax: 585.265.6678

www.fastenersdirect.com
sales@fastenersdirect.com

HEAVY HEX BOLTS—ASTM A193 GR B7, ASTM A307 GR A & B

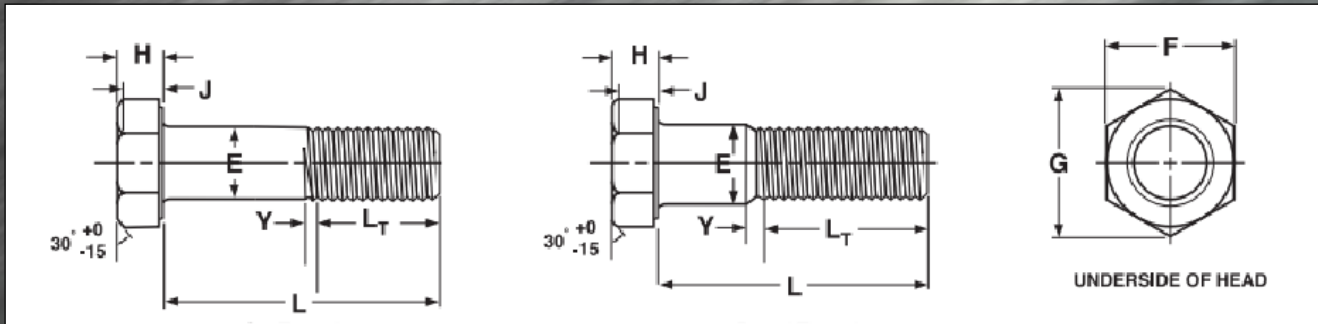

	Nominal Screw Size	Nominal Screw Length									
		Up to 1 in., incl.		Over 1 in. to 2-1/2 in., incl.		Over 2-1/2 in. to 4 in., incl.		Over 4 in. to 6 in., incl.		Longer than 6 in.	
Tolerance on Length	1/4 to 3/8	+0.02	-0.03	+0.02	-0.04	+0.04	-0.06	+0.06	-0.10	+0.10	-0.18
	7/16 and 1/2	+0.02	-0.03	+0.04	-0.06	+0.06	-0.08	+0.08	-0.10	+0.12	-0.18
	9/16 to 3/4	+0.02	-0.03	+0.06	-0.08	+0.08	-0.10	+0.10	-0.10	+0.14	-0.18
	7/8 and 1	-	-	+0.08	-0.10	+0.10	-0.14	+0.12	-0.16	+0.16	-0.20
	1-1/8 to 1-1/2	-	-	+0.12	-0.12	+0.16	-0.16	+0.18	-0.18	+0.22	-0.22
	Over 1-1/2	-	-	+0.18	-0.18	+0.20	-0.20	+0.22	-0.22	+0.24	-0.24



545 Basket Road
Webster, NY 14580

Toll Free: 800.691.0292 | Local: 585.265.1990 | Fax: 585.265.6678

www.fastenersdirect.com
sales@fastenersdirect.com

HEAVY HEX BOLTS—ASTM A193 GR B7, ASTM A307 GR A & B

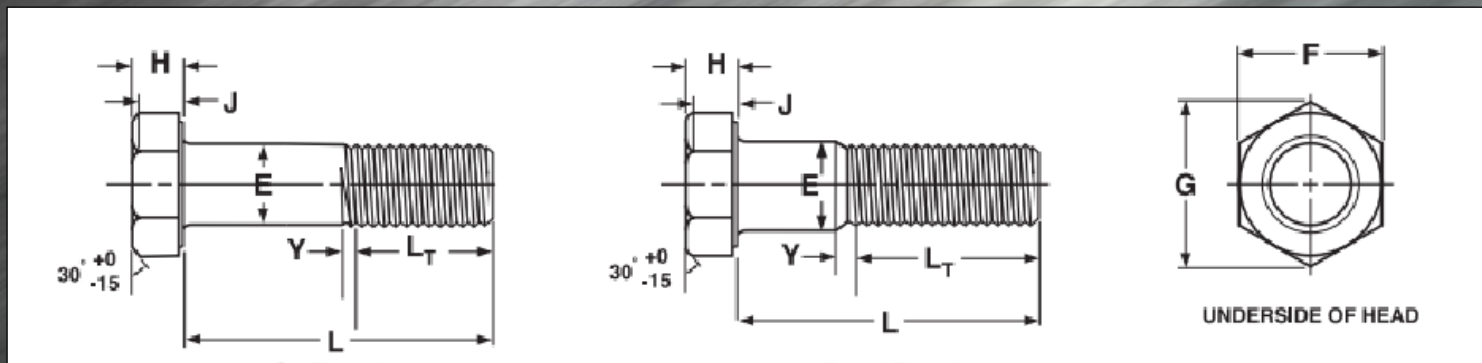

DESCRIPTION: An externally threaded fastener with a six-sided head that is wider than that of a standard hex bolt.

APPLICATIONS / ADVANTAGES: Offers greater wrenching area than standard hex machine bolts for use in heavy duty industrial work.

MATERIAL: Bolts shall be made from a carbon steel which conforms to the following chemical composition requirements — **Grade A:** Phosphorus 0.06% maximum, Sulfur 0.15% maximum—**Grade B:** Phosphorus 0.04% maximum, Sulfur 0.05% - **Grade B7:** Carbon 0.37-0.49%, Manganese 0.65-1.10%, Phosphorus 0.035% maximum, Sulfur 0.040% maximum, Silicon 0.15-0.35%, Chromium 0.75-1.20%, Molybdenum 0.15-0.25%

HARDNESS*:

Bolts less than three times diameter in length - **Grade A:** Rockwell B69—100, **Grade B:** Rockwell B69—95,
Grade A: Rockwell B100 maximum,
Grade B: Rockwell B69—95
Grade B7: Rockwell C 35 max

TENSILE STRENGTH: **Grade A:** 60,000 psi minimum; **Grade B:** 60,000—100,000 psi; **Grade B7:** 125,000 psi min. (all dia. thru 2-1/2")

ELONGATION IN 4D: **Grade A & B:** 18% minimum, **Grade B7:** 16% minimum (all dia. thru 4")