

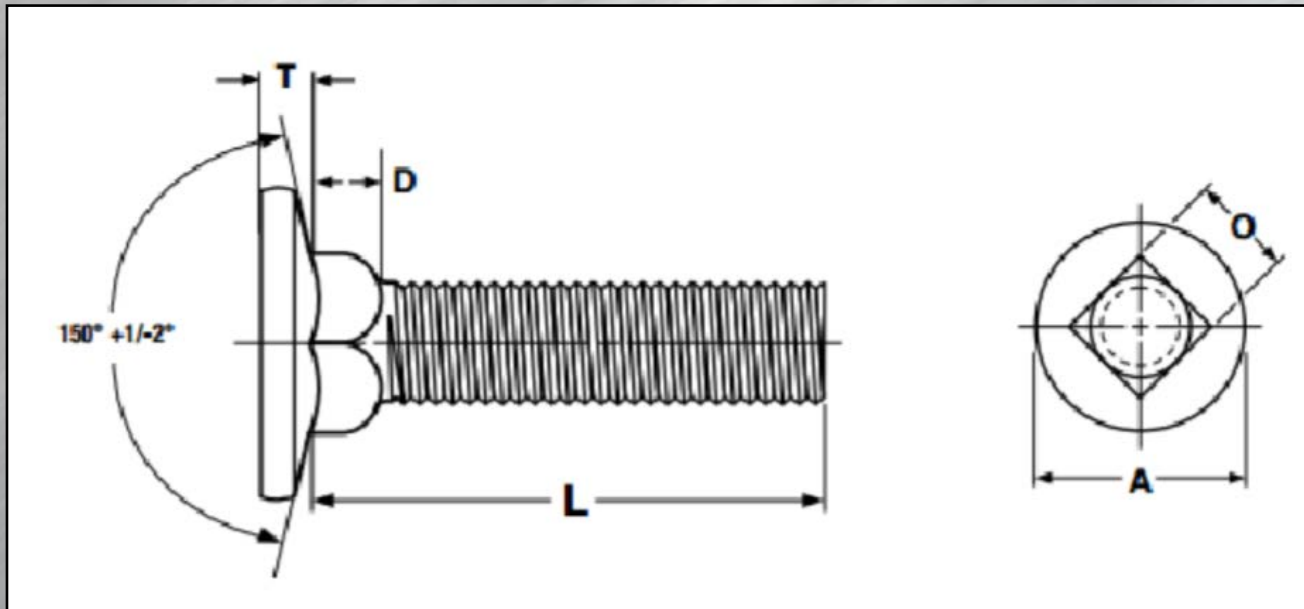

Toll Free 800.691.0292
 Fax 585.265.6678

sales@fastenersdirect.com
 cs@fastenersdirect.com
 www.fastenersdirect.com

FLAT HEAD CARRIAGE BOLTS, SQUARE NECK



Bolt Diameter & Thread Pitch	Head Diameter		Head Height		Square Width		Square Depth	
	A		T		O		D	
	Max	Min	Max	Min	Max	Min	Max	Min
1/4-20	.640	.590	.098	.078	.260	.245	.156	.125

TOLERANCE ON LENGTH: +0.02, -0.04



Toll Free 800.691.0292
Fax 585.265.6678

sales@fastenersdirect.com
cs@fastenersdirect.com
www.fastenersdirect.com

FLAT HEAD CARRIAGE BOLTS, SQUARE NECK

DESCRIPTION: A flat head bolt with a bearing surface; this is countersunk to a 150° angle. Although flat, the head has a measurable side height causing it to protrude above its mating surface when it's completely tightened. Directly below the head is a square neck and a threaded section that has a unified thread pitch.

APPLICATIONS / ADVANTAGES: The square neck design keeps the bolt from turning as a nut is tightened. The flat head featured gives a lower profile on the front or top side of the fastening than a round head carriage bolt. Designed specifically, but not exclusively, for the garage door industry.

PLATING: Flat head carriage bolts are usually supplied with a clear zinc finish.

MATERIAL	
GRADE 2	GRADE 5
AISI 1006 - 1025 Steel	AISI 1030 - 1055 Steel
CORE HARDNESS	
GRADE 2	GRADE 5
Rockwell B80 - B100	Rockwell C25 - C34
TENSILE STRENGTH	
GRADE 2	GRADE 5
74,000 psi min.	120,000 psi min.